

SCALE 1 : 10

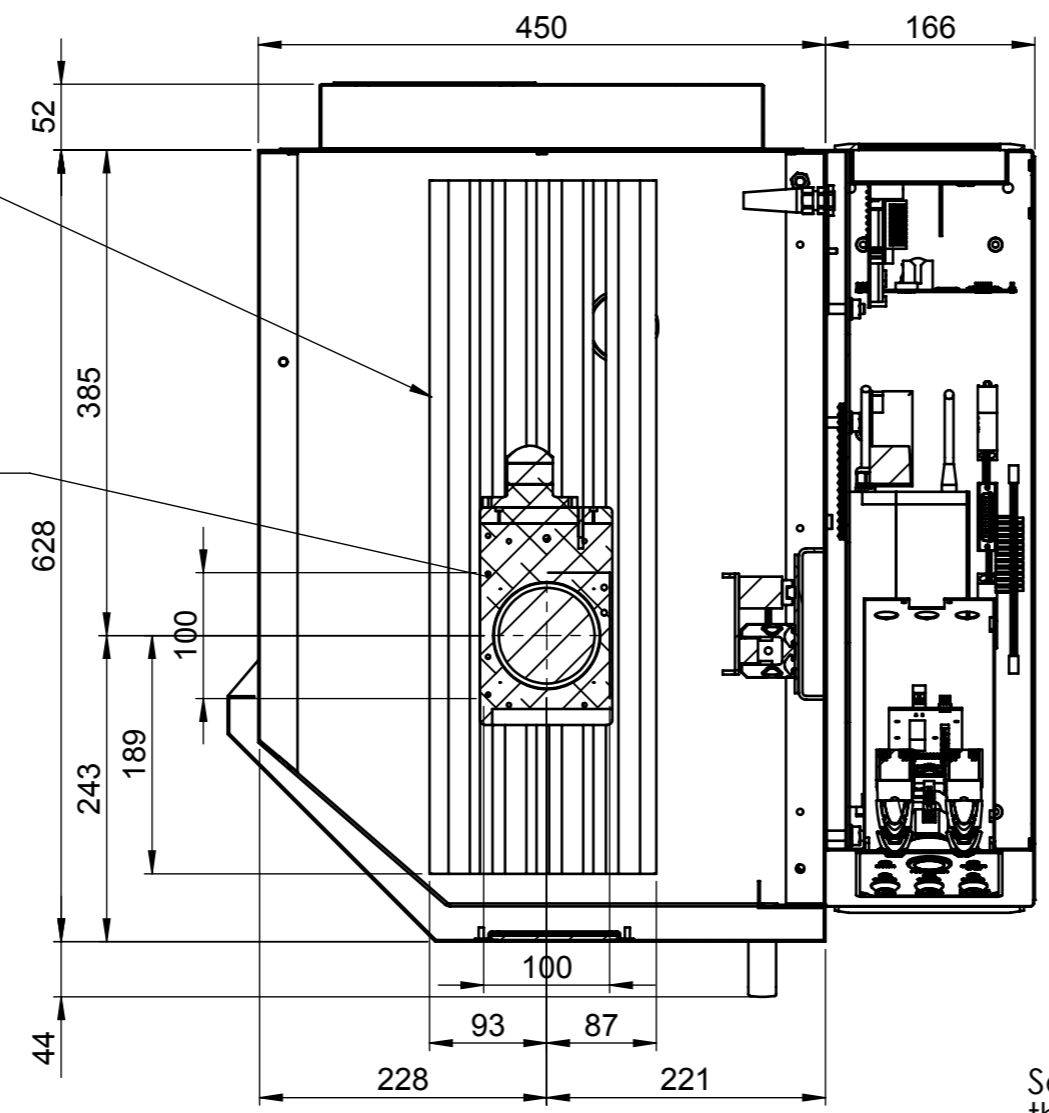

SECTION A-A
SCALE 1 : 6

Tee slotted work table.

This circle is a section thro the lens and is not a representation of the marking 'window'. The 'Window' is square, and its size varies with lens supplied. (100x100mm is a typical marking 'Window')

Section on tee slotted worktable area to show relationship of the Laser beam to the table and the internal walls of the enclosure.

REV	DATE	REV BY	DESCRIPTION
0	02/05/2014	rsmith	Initial Revision
-	-	-	-
-	-	-	-
-	-	-	-

PRYOR
MARKING TECHNOLOGY
© Edward Pryor & Son Ltd 2006

EDWARD PRYOR & SON LTD
EGERTON STREET,
SHEFFIELD, S1 4IX
TEL: +44 (0) 114 2766044
FAX: +44 (0) 114 2766890
enquiries@pryormarking.com
www.pryormarking.com

GENERAL TOLERANCE
NO DECIMAL PLACES +/- 0.5mm
ONE DECIMAL PLACES +/- 0.1mm
TWO DECIMAL PLACES +/- 0.03mm
THREE DECIMAL PLACES +/- 0.005mm
ANGULAR DIMENSIONS +/- 0.25 degree

MATERIAL:
FINISH:
TREATMENT:

CREATED BY: rsmith
CREATED ON: 01/05/2014
RELEASED BY: rsmith
RELEASED ON: 02/05/2014

TITLE:
Compact Laser, Complete Enclosure

DRG NO: 10035543 REV: 0

SIZE: A3 SCALE: 1:10 UNITS: mm UOS SHEET: 2 OF 3

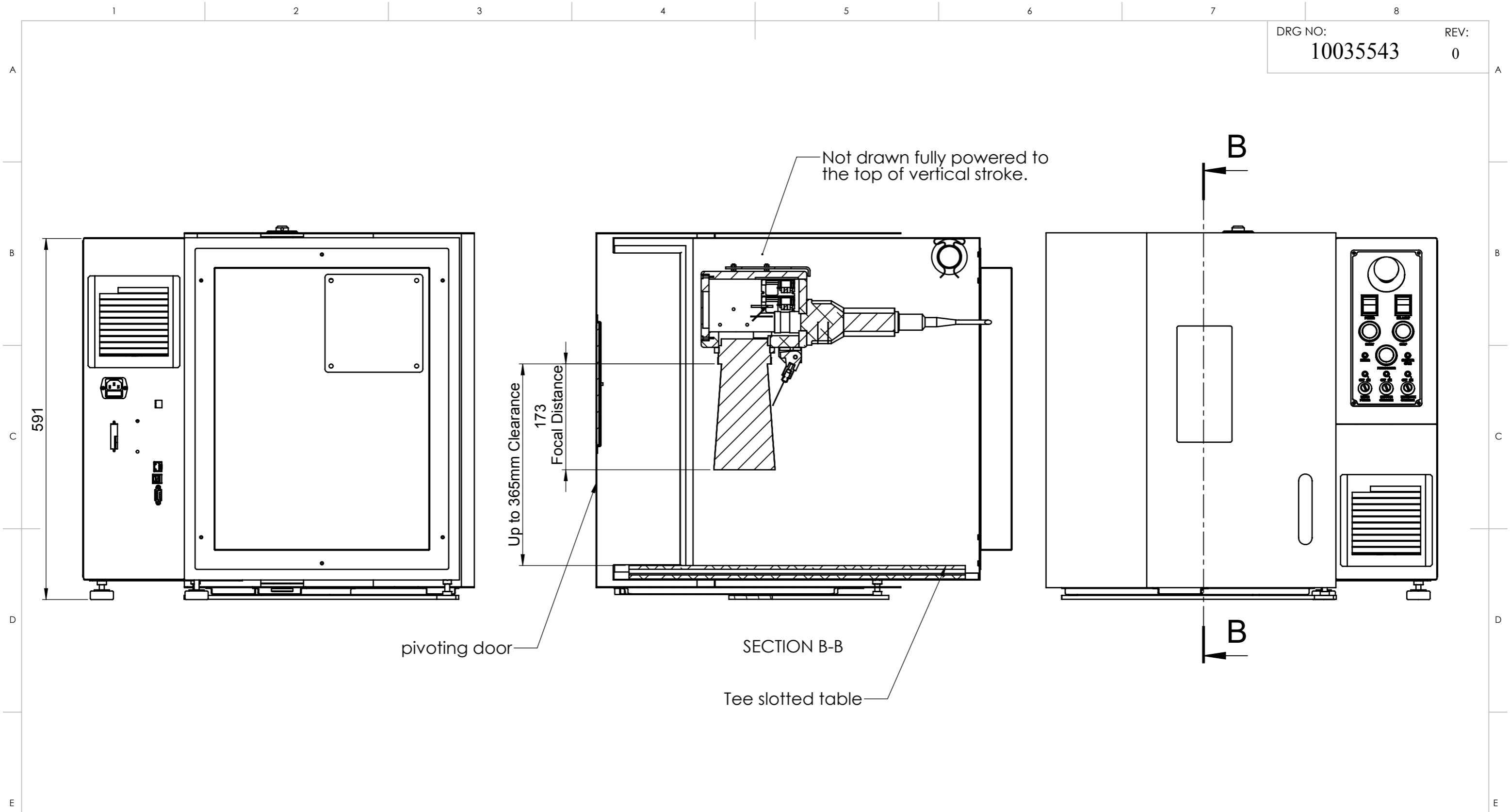

REV	DATE	REV BY	DESCRIPTION
0	02/05/2014	rsmith	Initial Revision
-	-	-	-
-	-	-	-
-	-	-	-

PRYOR
MARKING TECHNOLOGY
© Edward Pryor & Son Ltd 2006

EDWARD PRYOR & SON LTD
EGERTON STREET,
SHEFFIELD, S1 4IX
TEL: +44 (0) 114 2766044
FAX: +44 (0) 114 2766890
enquiries@pryormarking.com
www.pryormarking.com

GENERAL TOLERANCE
NO DECIMAL PLACES +/- 0.5mm
ONE DECIMAL PLACES +/- 0.1mm
TWO DECIMAL PLACES +/- 0.03mm
THREE DECIMAL PLACES +/- 0.005mm
ANGULAR DIMENSIONS +/- 0.25 degree

CREATED BY: rsmith
CREATED ON: 01/05/2014
RELEASED BY: rsmith
RELEASED ON: 02/05/2014

MATERIAL:
FINISH:
TREATMENT:

TITLE:
Compact Laser, Complete Enclosure

DRG NO: 10035543 REV: 0

SIZE: A3 SCALE: 1:6 UNITS: mm UOS SHEET: 3 OF 3